



*Innovation Excellence through
Global Manufacturing and Distribution*

Heat Seal Machines



AIT 120 | 240 CR

AIT 120 | 240 CR

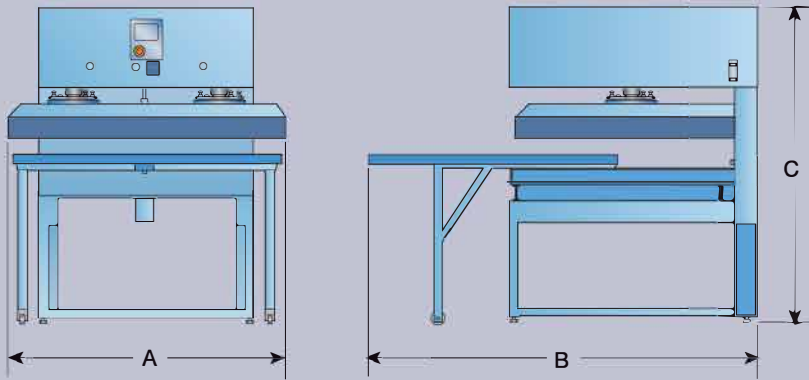

	A	B	C
AIT 120 CR	41"	77"	73"
AIT 240 CR	61"	87"	73"

	AIT 120 CR	AIT 240 CR
Dimension of the plate	30" x 40"	40" x 60"
Current	220	220
Temperature	40° - 285° C	40° - 285° C
Time adjustable	0-999, 9 sec.	0-999, 9 sec.
Net weight	1,540 lbs.	2,090 lbs.

Upper heating press especially designed for sublimation on fabric, metal, or rigid substrates.

Pressure can be easily regulated.

Temperature is regulated on the whole surface by three zones.

Open-sided design allows for the processing of oversized products outside of heated top platen.

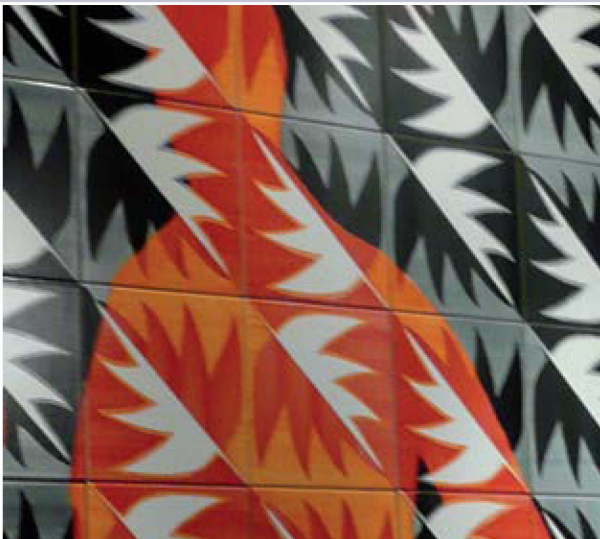

Advanced Innovative Technologies, LLC
 530 Wilbanks Drive, Ball Ground, GA 30107
 Tel. 770 479 1900 Fax: 770 479 4179

e-mail: info@aitequipment.com
 web: www.aitequipment.com